

Dobbelt kasse med TwinCONTACT

Varenr. 1650



- skrueløse fjederterminaler
- CEE og stikforbindelse SCHUKO® i ét kabinet
- med sikringsholder, maks. 10 A

Tekniske data

CEE 16 A, 5 p, 400 V	1
SCHUKO®	1
Fusing	• med sikringsholder, maks. 10 A
Beskyttelsestype	IP44
Lukker	false
Kabinetmateriale	Plast
Vægt	400 g
Overensstemmelseserklæring	VDE, EAC

Dimensioner

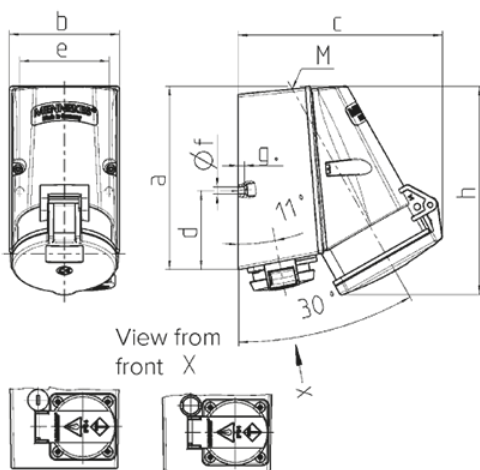

Drawing	Amp.	16		32
		Poles		
1 MB 354		4	5	5
Dim. in mm				
	a	141	141	141
	b	84	84	85
	c	136	140	158
	d	61	61	61
	e	68	68	68
	f	5.5	5.5	5.5
	g	5	5	5
	h	142	145	161
	M	25	25	25
Max. cable diam. (mm)		18	18	18
Terminal for cond. cross section (mm ²) min.-max.		1.5	1.5	2.5
		—4	—4	—10